

HAZARDOUS WASTE REGULATIONS

(Northern Ireland) 2005

The controls on
Hazardous Waste
& how they
affect you



Is your waste ...

HAZARDOUS

CORROSIVE

MUTAGENIC

EXPLOSIVE

REACTIVE

TOXIC

Do you use chemicals, products with hazard symbols or safety data sheets?

Then read on:

This leaflet is about controls on Hazardous Waste, those wastes which cause greatest environmental damage or are dangerous to human life. The controls:

- require you to notify the Regulator in advance of moving hazardous waste (**pre-notification**) by completing a form (**consignment note**);
- set out Fees for consignment notes;
- restrict the mixing of wastes.

INFECTIOUS

FLAMMABLE

OXIDISING

ECOTOXIC

TERATOGENIC

IRRITANT

HARMFUL

CARCINOGENIC

You need to know about the Regulations if you have to:

- dispose of;
- carry; or
- receive

Hazardous Wastes.

This includes Hazardous Wastes going to:

- Storage;
- Treatment; or
- Recycling or Disposal

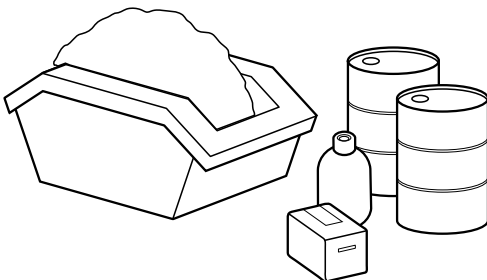

Definitions

What is waste?

Waste can be anything you own, or your business produces and which you want to get rid of. The publications listed on page 11 will help you decide whether something is waste.

What are Hazardous wastes?

These are dangerous wastes which display hazardous or toxic properties. They are listed in the List of Wastes Regulations (Northern Ireland) 2005. Some common hazardous wastes are listed on page 10.

These Regulations do not apply to Hazardous Waste from a domestic property, except where it is removed by another person for profit.

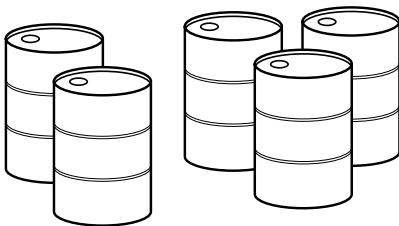

Procedures

in accordance with the Hazardous Waste Regulations (Northern Ireland) 2005

What happens if my waste is hazardous?

You must tell the Regulator before your hazardous waste is removed. This is called **pre-notification**. You do this by filling in a form called a **consignment note** which you may obtain from the Regulator. The Regulator must receive the form **at least** three clear working days before you want the waste moved.

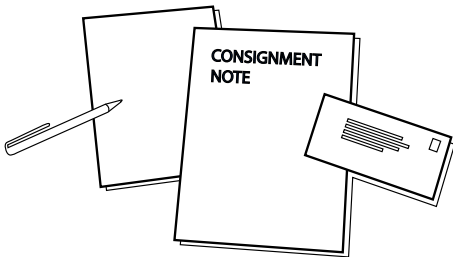

Who is the Regulator?

The Regulator is the Northern Ireland Environment Agency (NIEA), an Agency within the Department of the Environment.

Why Pre-notify?

The Regulator has to see that the waste is properly described and going to a suitable site. The paperwork also helps to track the waste to prevent illegal dumping. All of this helps to ensure that hazardous waste is handled properly - protecting the environment and preventing harm to human health.

How do consignment notes work?

If you want to get rid of waste?

You are the **consignor**

Before any hazardous waste leaves your site, you (or the person moving the waste - the carrier) must fill in parts A and B of a six copy consignment note. You (or the carrier) must send one copy to the Regulator. This must be done at least three clear working days, but not more than one month, before the waste is to be moved. You will be left with five copies. When the waste is about to be moved, the carrier must agree, with you, the information at parts A and B. The carrier will complete part C of the form. You must then sign part D. You must keep a copy and send one to the producer (if you are not the producer of the waste).

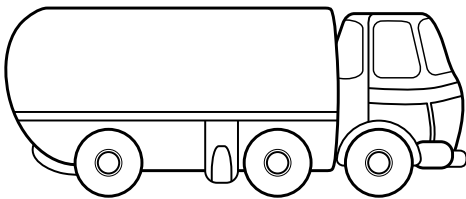

If I am moving the waste?

You are the **carrier**

Before any hazardous waste moves from the site, there must be five copies of the consignment note. You should check the information at parts A and B on each copy. You must complete part C of the form. If the details are not correct, you and the consignor should both agree any changes. These changes should only be minor - it would be sensible to prepare a new consignment note if there are major changes to the details. Once the consignor has signed and kept a copy (and a copy has been given to the producer, if different) you will be left with three copies of the form. Make sure they travel with the waste to the consignee. When you have delivered the waste, you must make sure that the person accepting it signs the form. You must keep a copy.

If I am receiving the waste?

You are the **consignee**

You must sign all three copies to say that you have accepted the load and that you are authorised to manage it properly. Return one copy to the carrier, keep one for yourself and send one copy to the Regulator. You are required to send a return to the producer. This may be a copy of the consignment note or a return containing the details specified in Schedule 8 of the Regulations.

Do I have to pre-notify each time?

Not necessarily. You can pre-notify a whole series of movements if they are repetitive - the same type of waste moving between the same places. However, each movement in the series will need a fresh consignment note. Each new consignment note must describe the waste in the batch properly, including the amount being moved. If your waste is removed on a carrier collection round, the carrier may complete all the paperwork.

Does everyone have to pre-notify?

Almost everyone, but there are some exceptions. For example, pre-notification is not needed for waste taken off ships in harbour; nor for materials being returned to manufacturers where they do not meet the specification. Consignments of lead-acid batteries will not require pre-notification.

Why are fees charged?

Fees enable the Regulator to meet the costs of supervising hazardous waste movements. A fee must be paid in relation to most consignments. **The level of fees will be reviewed periodically.**

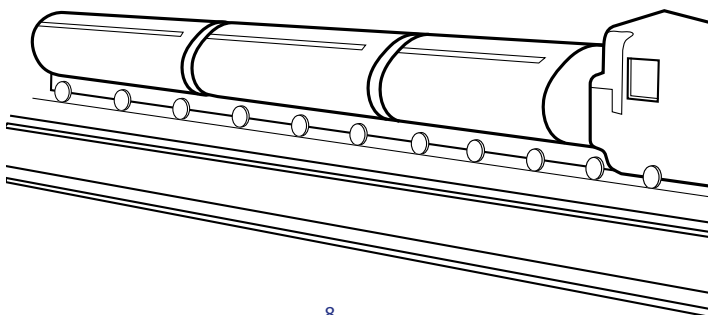

Other Matters

What records must I keep?

Consignors, carriers and producers **must** keep a register of the consignment notes copies for 3 years, but consignees where the waste remains on site will need to keep copies of the consignment notes until they surrender the licence for the site they manage.

Where the waste is moved off the site, consignee copies only need to be retained for 3 years.

Where can I get the consignment notes?

From the Regulator (see below)¹. Users and commercial suppliers are free to produce their own consignment notes. However general layout and wording will need to be followed, and they must still pay the relevant fee.

¹ Land & Resource Management
Northern Ireland Environment Agency
Klondyke Building
Cromac Avenue
Gasworks Business Park
Belfast
BT7 2JA

Tel: (028) 9056 9710

Fax: (028) 9056 9310

Are there fines for breaking the rules?

Yes - if a court convicts you of not complying with the Regulations you could suffer a fine of up to £5,000 and/or 2 years in prison.

The Regulator can also issue fixed penalty fines of £200 for certain offences.

List of typical Hazardous Wastes

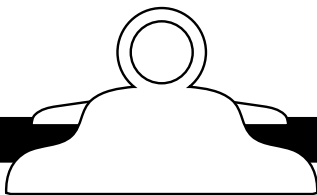

Acids
Alkaline solutions
Asbestos
Batteries*
Dental amalgam
Fluorescent tubes
Fly ash*
Fridges containing CFCs
Industrial solvents
Oily sludges
Pesticides
Photographic chemicals
Printer toner cartridges*
Television and computer screens
Waste oils
Wood preservatives

**not all may be hazardous*

More Information and Contacts Page

Definition of Waste - advice on what is waste

The Waste and Contaminated Land
(Northern Ireland) Order 1997
S.I. 1997/2778(N.i 19) ISBN 0-11-065195-2

Hazardous Waste - Procedures and advice on what waste is hazardous

The Hazardous Waste Regulations (Northern
Ireland) 2005 (S.R 2005 No. 300)
ISBN 0-337-96064-X

List of Wastes Regulations (Northern Ireland)
2005 (S.R 2005 No. 301) ISBN 0-337-96095-X

Hazardous Waste: Interpretation of the
Definition and Classification of Hazardous
Waste (Technical Guidance WM2)
(2nd Edition v2.2) ISBN 1-84432-1304

Technical Guidance Notes in Preparation

A Guide to Hazardous Waste Regulations
(Northern Ireland) 2005

Transport Regulations - advice about moving dangerous goods

The Carriage of Dangerous Goods and
Use of Transportable Pressure Equipment
(Amendment) Regulations (Northern Ireland)
2006 (S.R 2006 No. 525) ISBN 0-337-96776-8

European Agreement concerning the
International Carriage of Dangerous Goods by
Road - ADR 2007 (Set of Book and CD-ROM)
ISBN 92-1-139119-9

*The Carriage of Dangerous Goods by Rail
Regulations (Northern Ireland) 1998
ISBN 0-337-93145-3

* Amended by the Carriage of Dangerous Goods
(Amendment) Regulations (Northern Ireland) 2002

Transport Regulations - advice about moving dangerous goods (continued)

The Carriage of Dangerous Goods (Amendment) Regulations (Northern Ireland) 2002 (S.R 2002 no. 34) ISBN 0-337-94151-3

The Dangerous Substances in Harbour Areas Regulations (Northern Ireland) 1997 ISBN 0-337-10509-X

Approved Carriage list - Information approved for the classification, packaging and labelling of dangerous goods for carriage by road and rail other than explosive and radioactive material ISBN 0-7176-1681-9

Approved Requirements and Test Methods for the Classification and Packaging of Dangerous Goods for Carriage ISBN 0-7176-1221-X

For further information on Asbestos contact
The Asbestos Advisory Service
Health and Safety Executive Northern Ireland
83 Ladas Drive, Belfast BT6 9FR
Freephone 0800 032 0121
email:asbestos@detini.gov.uk

You can buy any of the above at The Stationery Office,
Government Bookshop, 16 Arthur Street, Belfast
Tel: (028) 9023 8451

Our aim is to protect, conserve and promote the natural and built environment for the benefit of present and future generations.

**Northern Ireland Environment Agency
Klondyke Building
Cromac Avenue
Gasworks Business Park
Belfast BT7 2JA
T. 0845 302 0008**

www.ni-environment.gov.uk



An Agency within the Department of the

Environment

www.doeni.gov.uk



INVESTOR IN PEOPLE